

1.25Gb/s Burst Mode Transimpedance Amplifier with Wide Dynamic Range and Precision Current Monitor for GPON/EPON OLT Receiver

MG3122 is a burst mode TIA with high optical sensitivity (-36dBm with APD), wide input dynamic range, and high overload tolerance (greater than 4mA_{pp}). MG3122 consume very small current of 22mA. It can be used either in differential or single ended mode. With Mignal’s novel instant AGC techniques, MG3122 can satisfy burst mode receiver timing requirements for both GPON and EPON OLT receivers.

Features

- Data rates up to 1.25Gb/s
- Sensitivity: -36dBm(APD)
- Input current overload : 4mA_{pp}
- 4kΩ typical differential transimpedance
- Precision and fast I-source monitor
- Optional Internal bias for PIN diode
- I-source monitor for PIN and APD
- 0Hz low cutoff frequency
- Single +3.3V supply, typical current 22mA

Applications

- GPON/EPON OLT Receivers
- Fully Compliance with ITU-T G.984.x
- Pads comparable to 408B and 2036
- Work with 88933 and 88149
- Serial Digital Video Receiver(1.485Gbp ,HD-SDI)

TO Bonding Diagrams

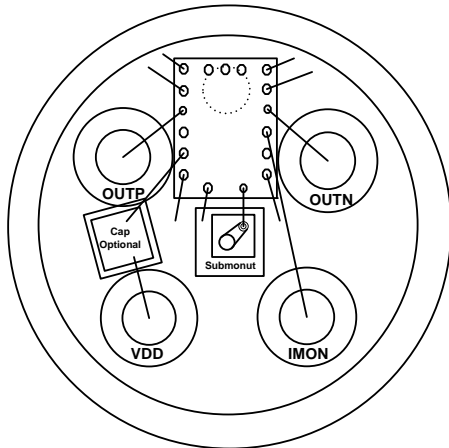

1) 5 pin TO bonding for PIN with precision IMON

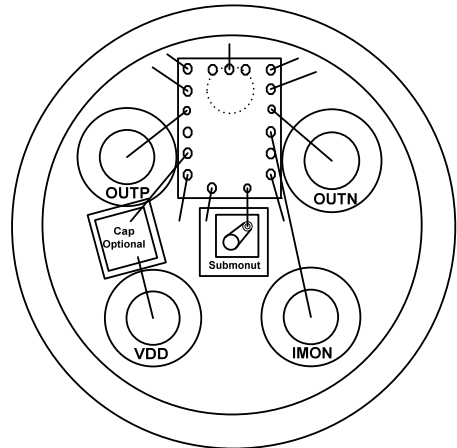

2) 5 pin TO bonding for PIN with fast IMON

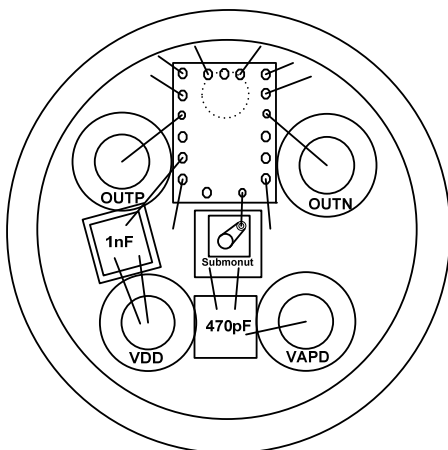

3) 5 pin TO bonding for APD w/o IMON

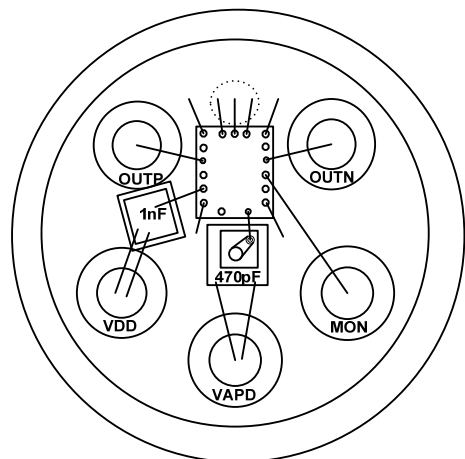

4) 6 pin TO bonding for APD with fast IMON

Pad Diagram

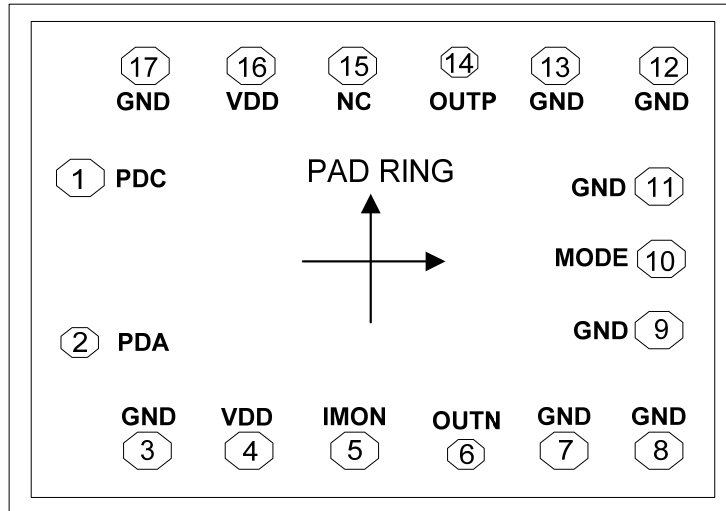

Application Diagrams

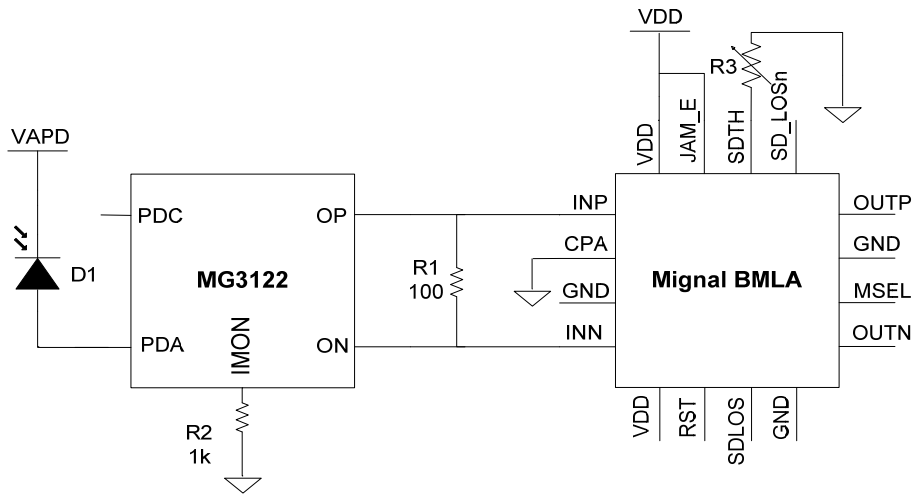

MG3122 works with Mignal's Burst Mode Limiting Amplifier

1.0 Electrical Specifications

1.1 Absolute Maximum Ratings

Absolute maximum ratings are the values of voltage, current, temperature, power dissipation etc., which should not be exceeded at any time, otherwise deterioration or destruction of the IC may take place.

Parameter	Min	Max	Units
Power supply (VCC - GND)	-0.5	4	V
Storage temperature	-55	150	°C
Input current	0	5	mA

1.2 Recommended Operating Conditions

Parameter	Min	Max	Units
Power supply (VCC - GND)	2.97	3.63	V
PD capacitance for 1.25Gbps	0.5	0.7	pF
Operating ambient temperature	-40	95	°C

1.3 DC Characteristics

Symbol	Parameter	Min	Typ	Max	Units
VB	Photodiode bias voltage (PDC - PDA)		2.0		V
VCM	Common mode output voltage	Vcc-1.3	Vcc-1.0	Vcc-0.7	V
IDD	Supply current (Mode floating for slow IMON)	18.5	21.5	23.5	mA
IDD	Supply current (Mode pad tied to GND for fast IMON)		28	32	mA
RLOAD	Recommended differential output load	-	100	-	Ω

1.4 AC Characteristics

Typical conditions: T = 25 °C, VCC = 3.3V, C = 0.5 pF, L = 1.0 nH

Parameter	Conditions	Min	Typical	Max	Units
Small Signal Bandwidth	Input below AGC on		1000		MHz
Small Signal Low Frequency Cut-off	Dc coupled		0		kHz
Small Signal Transimpedance (diff)	Input 8μA-pp		4		kΩ
Input Referred Noise (RMS)	1.25Gbps application		100		nA
Optical Input Sensitivity with APD	BER=10 ⁻¹²		-36		dBm
Overload Input Current			2		mA
Differential Output Swing	Input 2μ-4mA _{pp}			120	mV _{pp}
Output DC Offset Voltage	Input 2mA _{pp}			200	mv
Differential Output Impedance			100		Ω
Photo current monitor offset			0		μA
Photo current monitor Gain Ratio	Input: 10μA to 2mA	0.90	1	1.10	
Power Supply Rejection Ratio	DC to 4MHz		25		dB

2.0 Functional Description

2.1 Function Overview

MG3122 is a burst mode transimpedance amplifier. Its main function is to convert input light pulse stream into output voltage pulse stream across wide input range and over various environment conditions. Its secondary function is to provide a current sourcing monitor as an indicator of average optical signal strength. It can also provide voltage bias for PIN photo detector. Additionally, MG3122 have a small DC offset voltage between two differential outputs.

2.2 Instant AGC

For large input current pulses, a novel gain control circuit (AGC) in MG3122 will be activated instantly to attenuate the transfer response of TIA. This instant and soft AGC circuit turns on gradually and does not cause significant waveform distortion

2.3 PD Bias and Monitor Output Configuration

In addition to converting high speed current input to voltage output, MG3122 can provide a current sourcing monitor for the input optical power, and it also provides voltage bias for pin diode. The functions provided through two pads, IMON and VPD, can be set to operate in different modes by tying Mode pad to GND or letting it float. Table 2-1 provides detailed settings for these two pads.

Table 2-1. IMON and VPD output modes with different MODE connections

MODE Settings	IMON	VPD	Notes
Floating	Sourcing: average PDC current	Fixed Voltage Bias: Vdd-0.5V	Precision average current measurement on PD cathode and filtered biasing for PIN diode
Tied to GND	Sourcing: average PDA current	Bias through 500Ω Resistor and 10pF Capacitor	Fast average current measurement on PD anode, especially for APD application

2.4 IMON functions

Pad MODE controls the operation modes of IMON pad. If MODE is floated, IMON sources a current that is equal to the current though pad PDC. Typically this is for PIN diode application. If MODE is tied to GND, IMON sources a current that is equal to the current though pad PDA. When MG3122 is operating in the latter mode, its supply current is about 5mA higher. In APD application, since pad PDC is not connected, MODE pad has to be connected to GND for IMON current sourcing monitor to work.

When MODE pad is tied to ground, MG3122's IMON function is also operated in fast mode, i.e. IMON sourcing current settles faster around its final value. In this mode, it takes about 500ns to 1us to reach its final value depending to types of input data patterns.

3.0 Applications Information

3.1 TO-CAN Bonding:

MG3122 can be bonded in four ways for different applications: 1) 5 pin TO for APD without IMON, 2) 6 pin TO for APD with fast IMON, 3) 5 pin TO for PIN diode with precision IMON, 4) 5 pin TO for PIN diode with fast IMON. VCC bonding wire de-coupling capacitor and PIN diode cathode capacitor are optional. If provided, they can help to reduce the bonding wire coupling.

Pad MODE controls the operation modes of IMON pad. If MODE is floated, IMON sources a current that is equal to the current though pad PDC. If MODE is tied to GND, IMON sources a current that is equal to the current though pad PDA.

3.2 TO Assembly

Typical recommended assembly of TIA in optical TO header is shown in Figure 3-1. MG3122 is designed to work with bond wire inductance of ~1nH. Metal Shim is often required to raise TIA so that bonding pads are horizontally in the same level as photo diode which is typically mounted on a ceramic sub-mount for appropriate focal length.

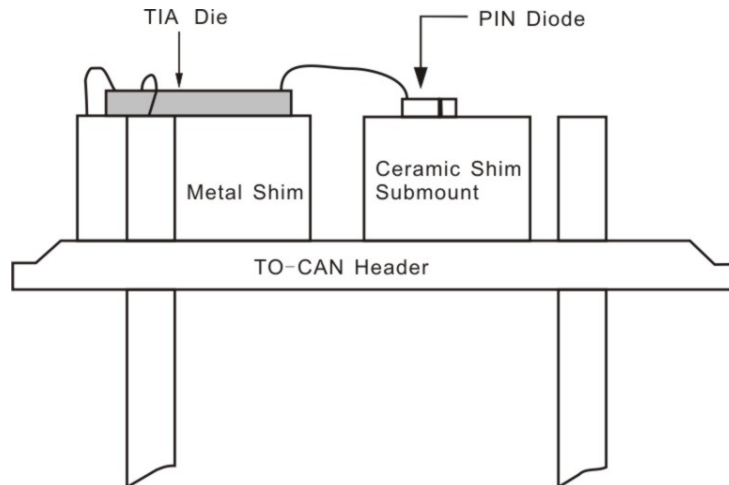

Figure 3-1 Suggested PIN Diode Connection Methods

4.0 Die Specifications

4.1 Pad Descriptions

Die Pad	Name	Function
1	PDC	PIN PD Common input. Connect to photo diode cathode (and optional cap).
2	PDA	Active PIN input. Connect to photo diode anode.
3,7-9,11-13,17	GND	Ground pin. Connect to the most negative supply (at least connect 4 GND).
4,16	VCC	Power pin. Connect to most positive supply (only one VCC pad needs to be connected).
5	IMON	Analog current source output. Current matched to average photodiode current.
6	OUTN	Differential data output negative (goes low as light increases).
10	MODE	Monitor PDA (anode) average current when this pad tied to ground; Monitor PDC(cathode) average current when this pad not connected.
14	OUTP	Differential data output (goes high as light increases).
15	NC	Not used for normal operation.
NA	Backside	Backside. Connect to the lowest potential, usually ground.

4.2 Pad Coordinates

Pad Number	Pad	X	Y	Pad Number	Pad	X	Y
1	PDC	-430	100	10	MODE	434	0
2	PDA	-430	-100	11	GND	434	150
3	GND	-375	-334	12	GND	434	329
4	VDD	-228	-329	13	GND	228	329
5	IMON	-76	-329	14	OUTP	76	329
6	OUTN	76	-329	15	NC	-76	329
7	GND	228	-329	16	VDD	-228	329
8	GND	434	-329	17	GND	-375	334
9	GND	434	-150				

4.3 Other Notes

Die Thickness: 250µm
 Die Size: 1060 µm x 840 µm
 Pad Materials: Aluminum